

870-2, 871-2

Pneumatic Power Clamps | Ordering Information

870-2

Base Model	Description
870-2	38,1 mm [1.5 in.] Cylinder with Vertical Clamp Arm
871-2	38,1 mm [1.5 in.] Cylinder with Horizontal Clamp Arm

Sensors	Description (order separately)
BIM-IKE-AP	Magnetic Sensor, 2 pieces required
810151	Magnetic Sensor, 2 pieces required
810153	Magnetic Sensor, 2 pieces required
810155	Magnetic Sensor, 2 pieces required
810157	Magnetic Sensor, 2 pieces required

See below for sensor specifications.



871-2

Max Holding Torque
260 Nm [192 ft-lb]
Max Clamping Torque
60 Nm [44 ft-lb]
at 5 bar [72 psi]

870-2

Max Holding Torque
260 Nm [192 ft-lb]
Max Clamping Torque
60 Nm [44 ft-lb]
at 5 bar [72 psi]

870-2, 871-2

Pneumatic Power Clamps | Dimensions and Technical Specifications

Power clamps with the roller and cam principle

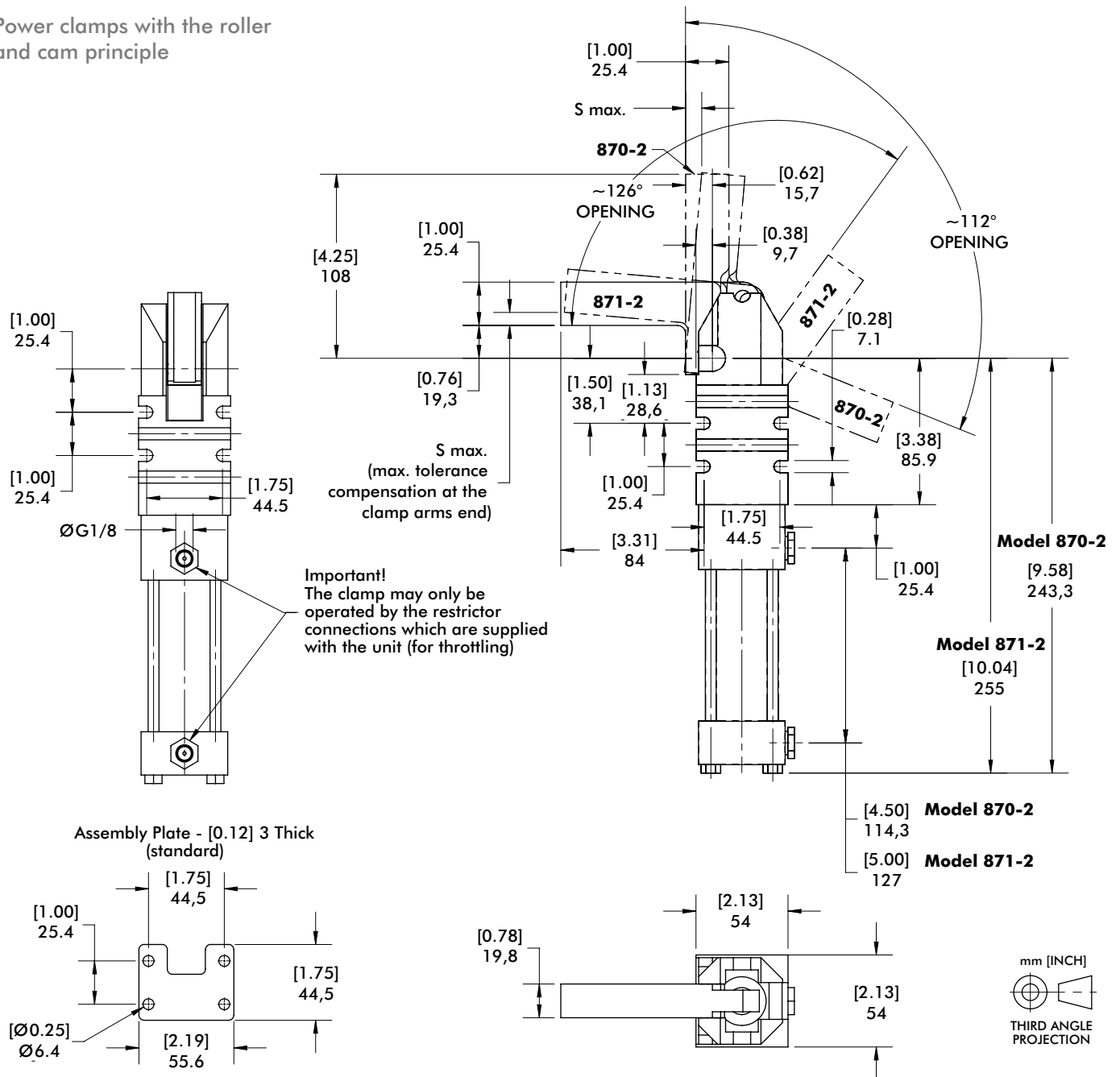

Model	Connection	S Max. Max. Tolerance Compensation at the Clamp Arms End [ft lb] Nm	Max. Operating Pressure [psi] bar	Cylinder Ø [in.] mm	Opening Angle	Weight [lbs] kg	Air Consumption per double stroke at 5 bar dm ³ [ft ³]
870-2	G 1/8	[3] 4,5	[145]	[1.50]	112°	[6.60]	0,95 [0.03]
871-2		[3] 3,5	10	38,1	118°	3	

Sensor Options	Mount Style	Connector	Length	Function	Voltage	Max. Switching Current	Voltage Drop
BIM-IKE-AP	Tie Rod	No connector cord	2m [6.6 ft.]	PNP	10-30V DC	200mA	2.3V
810151				Reed	5-120V AC/DC	500mA	3.5V
810153			Reed	24-240V AC	4A	1.0V	
810155			PNP	6-24V DC	500mA	1.0V	
810157			NPN	6-24V DC	500mA	1.0V	