

FAG

**7602015-TVP**

Axial angular contact ball bearing

Schaeffler ID:  
0191191940000Axial angular contact ball bearing 7602..-  
TVP, single direction, no screw mounting

## Technical information

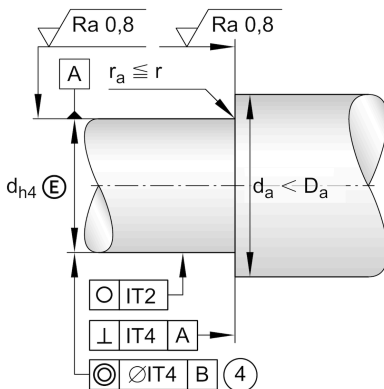
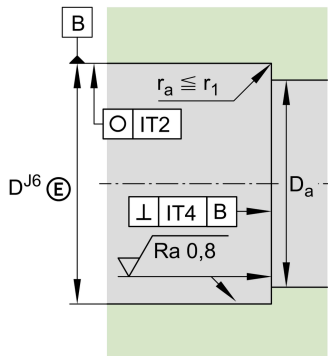
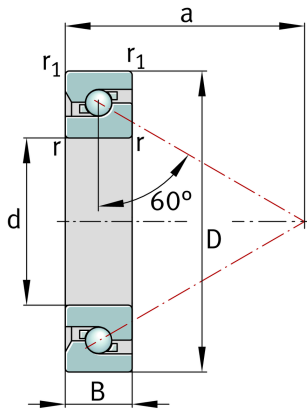
**Main Dimensions & Performance Data**

d	15 mm	Bore diameter
	0 mm	Bore diameter upper tolerance
	-0,004 mm	Bore diameter lower tolerance
D	35 mm	Outside diameter
	0 mm	Outside diameter upper tolerance
	-0,006 mm	Outside diameter lower tolerance
B	11 mm	Width
	0 mm	Width upper tolerance
	-0,08 mm	Width lower tolerance
C <sub>a</sub>	13.100 N	Basic dynamic load rating, axial
C <sub>0a</sub>	24.700 N	Basic static load rating, axial
C <sub>ua</sub>	1.120 N	Fatigue load limit, axial
n <sub>G Grease</sub>	12.300 1/min	Limiting speed for grease lubrication
n <sub>g</sub>	6.700 1/min	Thermally safe operating speed
≈m	0,05 kg	Weight

**Mounting dimensions**

D <sub>a</sub>	30 mm	Diameter of housing
D <sub>a</sub>	H12	Diameter of housing clearance
d <sub>a</sub>	20,5 mm	Diameter shaft
d <sub>a</sub>	h12	Diameter shaft clearance

**Dimensions**

r <sub>min</sub>	0,6 mm	Minimum chamfer dimension
r <sub>1 min</sub>	0,6 mm	Minimum chamfer dimension
a	27,5 mm	Distance between the apexes of the pressure cones
α	60 °	Contact angle

**Temperature range**

T <sub>min</sub>	-30 °C	Operating temperature min.
T <sub>max</sub>	120 °C	Operating temperature max.

### Additional information

$M_R$	0,02 Nm	Bearing frictional torque
$c_{aL}$	516 N/ $\mu$ m	Rigidity axial
	2 $\mu$ m	Axial runout
	ZM15	Recommended INA precision locknut for radial locking
	AM15	Recommended INA precision locknut for axial locking
$M_A$	10 Nm	Tightening torque for the recommended INA precision locknut
	5.740 N	Required locknut force axial