**FAG****54220**

Axial deep groove ball bearing

Axial deep groove ball bearing 542, double direction, with spherical housing washer, steel sheet metal cage

Technical information

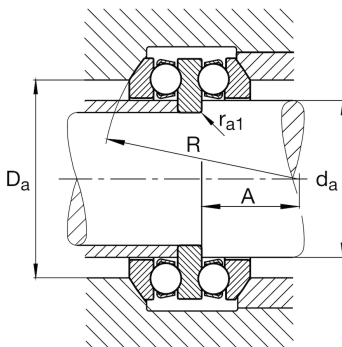
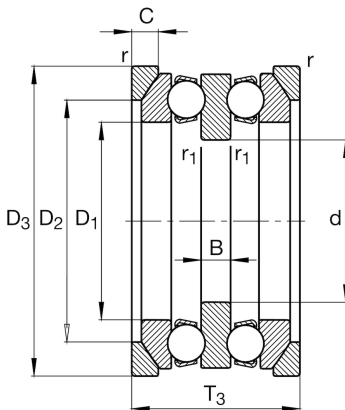
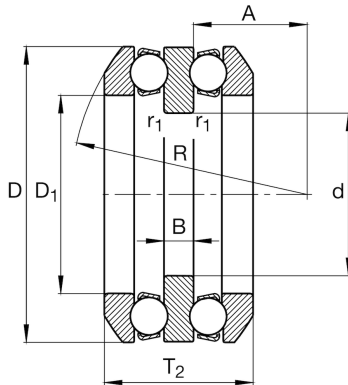

Main Dimensions & Performance Data

d	85 mm	Inner diameter shaft washer
D	150 mm	Outer diameter housing washer
T ₂	72,8 mm	Height
C _a	119.000 N	Basic dynamic load rating, axial
C _{0a}	325.000 N	Basic static load rating, axial
C _{ua}	13.300 N	Fatigue load limit, axial
n _G	2.700 1/min	Limiting speed
n _{gr}	3.550 1/min	Reference speed
≈m	3,905 kg	Weight

Mounting dimensions

d _{a max}	100 mm	Maximum diameter shaft shoulder
D _{a max}	125 mm	Maximum diameter of housing shoulder
r _{a max}	1 mm	Maximum filled radius
r _{a1 max}	1 mm	Maximum filled radius

Dimensions

D ₁	103 mm	Inner diameter housing washer
B	15 mm	Height shaft washer
r _{min}	1,1 mm	Minimum chamfer dimension
r _{1 min}	1 mm	Minimum chamfer dimension
R	112 mm	Radius spherical housing washer
A	49 mm	Distance of the center point
T ₃	81 mm	Height with seat washer

Temperature range

T _{min}	-30 °C	Operating temperature min.
T _{max}	150 °C	Operating temperature max.

Calculation factors

A	0,68	Minimum load factor
---	------	---------------------



View product details on medias

10.04.2024, 16:09:21 CEST

SCHAEFFLER

Additional information

U220

Seat washer

