

The job of the filter is to retain liquid or solid impurities present in the compressed air. The incoming air is moved by the centrifuge unit, so that liquid particles, which are heavier, are projected against the walls of the container and force to adhere to it. As they accumulate, they create drops that deposit on the bottom by gravity. The remaining solid particles are held back by the porous filtering element. The condensate is maintained in a quiet state to prevent the deposited impurities from re-entering the circulation. The condensate drains out through the drain cock provided. The RMSA drain discharges when the pressure in the filter drops to zero. Alternatively the condensate can be drained by hand by pressing the button. The RA drain discharges condensate from the container automatically whenever necessary, regardless of the pressure level. The SAC tap drains the condensate only as the result of sudden changes in compressed air requests. On the front and back there is a port (1/8" for size 1 and 1/4" for size 2) that can be used with pressure gauges, pressure switches or as an additional filtered air intake.



TECHNICAL DATA	FIL SY1			FIL SY2				
	1/8"	1/4"	3/8"	3/8"	1/2"	3/4"	1"	
Threaded port								
Degree of filtration	5 (yellow) - output air purity class ISO8573-1: 3.7.4 20 (white) - output air purity class ISO8573-1: 4.7.4 50 (blue) - output air purity class ISO8573-1: 5.7.4							
Max. input pressure	bar			13				
	MPa			1.3				
Flow rate at 6.3 bar (0.63 MPa; 91 psi) ΔP 0.5 bar (0.05 MPa; 7 psi)	psi			188				
	Nl/min	900	1200	1300	3400	3800	3800	
Flow rate at 6.3 bar (0.63 MPa; 91 psi) ΔP 1 bar (0.1 MPa; 14 psi)	scfm	32	42	46	120	135	135	
	Nl/min	1300	1650	1750	4500	5200	5200	
Min/max temperature at 10 bar; 1 MPa; 145 psi	scfm	46	58	62	159	184	184	
	°C	From -10 to +50			From -10 to +50			
Weight	g	178	173	164	488	461	457	
Condensate drain	RMSA: drain with manual condensate discharge and automatic discharge at zero pressure RA: automatic drain with condensate discharge, independent of pressure and flow rate. Version conveys the draining by inserting the pipe having internal diameter 6 mm in the lower port. SAC: automatic drain with condensate discharge. Operates by depression - requires variable air take-offs. Note: the maximum input pressure for the RA version must not exceed 10 bar							
Fluid	Compressed air or other inert gases							
Condensate bowl capacity	cm³	30			70			
Mounting position		Vertical			Vertical			
Port for additional air take-off		1/8", front and rear			1/4", front and rear			
Additional air take-off flow rate at 6.3 bar (0.63 MPa; 91 psi) ΔP 1 bar (0.1 MPa; 14 psi)	Nl/min	500			1500			
	scfm	18			53			

UNITS
Syntesi® FILTER

COMPONENTS

- ① Technopolymer filter body
- ② IN/OUT bushing made of OT58 nickel-plated brass or passivated aluminium for 3/4" - 1"
- ③ Technopolymer centrifuge
- ④ Sintered HDPE filter cartridge
- ⑤ Technopolymer screen
- ⑥ Drain (RMSA)
- ⑦ Technopolymer plate
- ⑧ NBR o-ring gaskets
- ⑨ Clear technopolymer bowl

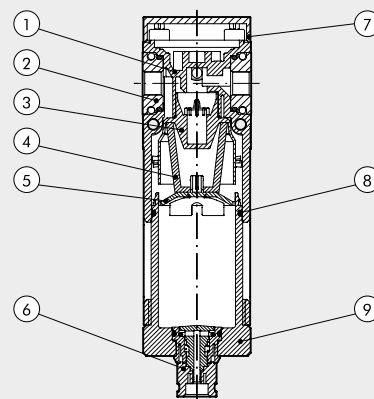

FLOW CHARTS

FIL Syntesi® SY1 1/8"

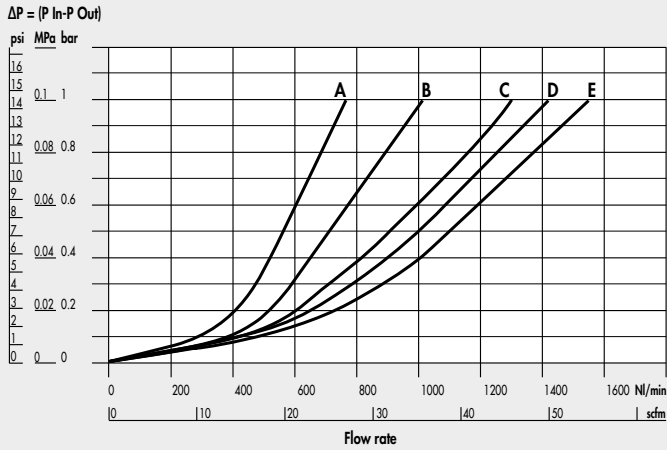

FIL Syntesi® SY1 1/4"

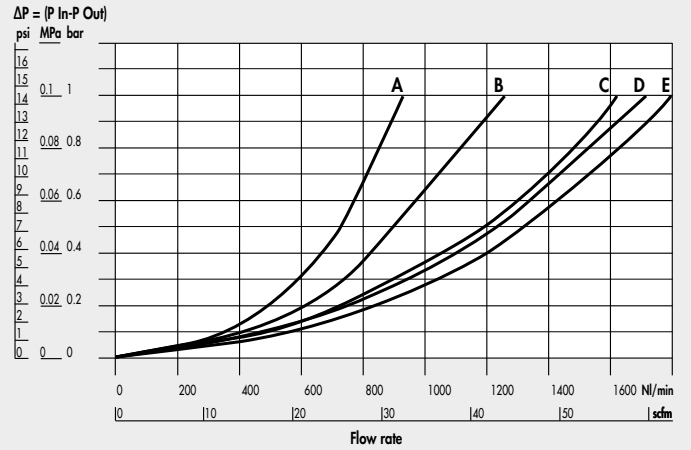

FIL Syntesi® SY1 3/8"

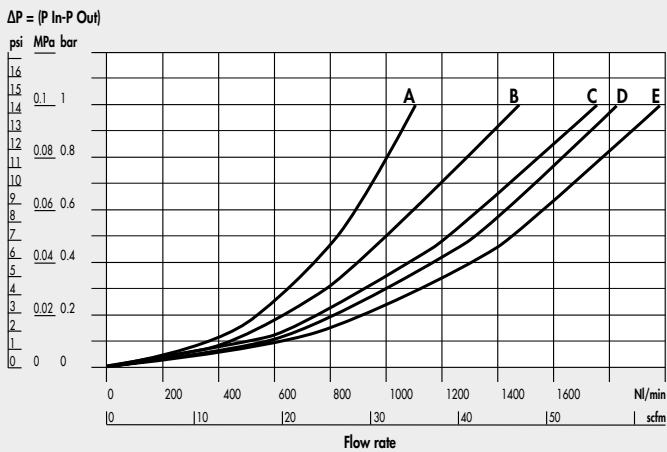

FIL Syntesi® SY2 3/8"

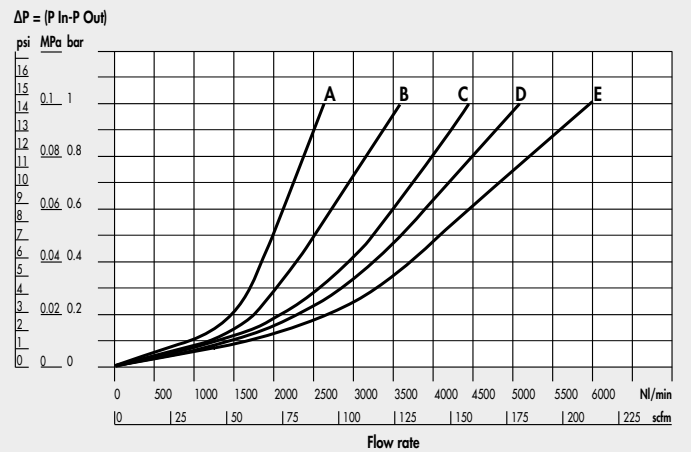

FIL Syntesi® SY2 1/2"

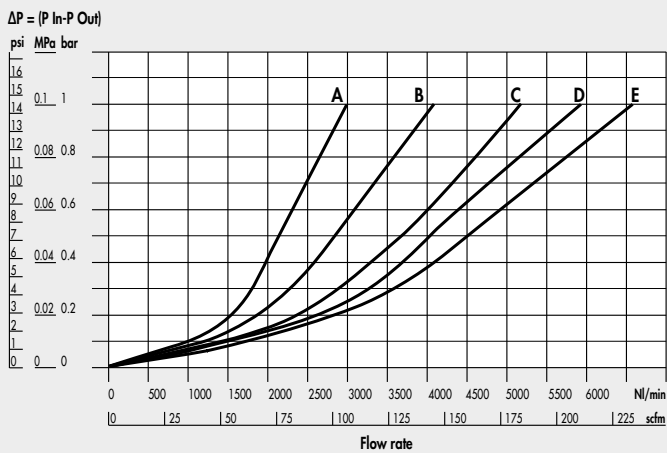

FIL Syntesi® SY2 3/4"-1"

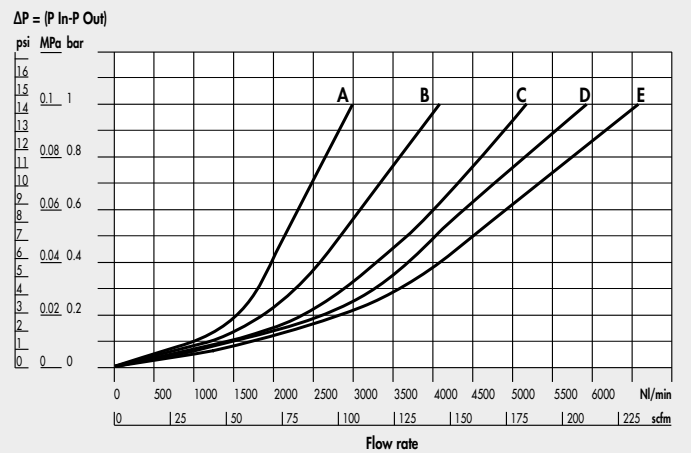

A = 2.5 bar - 0.25 MPa - 36 psi
 B = 4 bar - 0.4 MPa - 58 psi

C = 6.3 bar - 0.63 MPa - 91 psi
 D = 8 bar - 0.8 MPa - 116 psi

E = 10 bar - 1 MPa - 145 psi

