

SHORT-STROKE CYLINDER SERIES SSCY



ACTUATORS

SHORT-STROKE CYLINDER – SERIES SSCY

Compact cylinders suitable for installation in limited spaces:

- configuration with or without magnet
- single or double-acting - single or through-rod
- anti-rotation version and with built-in fixings
- possible choice of NBR, POLYURETHANE or FKM/FPM gaskets
- special design on request.



TECHNICAL DATA		Ø12	Ø16	Ø20	Ø25	Ø32	Ø40	Ø50	Ø63	Ø80	Ø100	
Max operating pressure	bar						10					
	MPa						1					
	psi						145					
Temperature range	POLYURETHANE						-10 to +80					
	NBR						-10 to +80					
	FKM/FPM						-10 to +150 (non-magnetic cylinders)					
	Low Temperature						-35 to +80					
Design							With profile					
Fluid		Unlubricated air. Lubrication, if used, must be continuous										
Standard strokes †	single-acting	5 to 25			5 to 50			-				
	double acting	5 to 50			5 to 70			5 to 110		5 to 150		
	anti-rotation				5 to 120			5 to 150		5 to 150		
	perforated through-rod				5 to 100			5 to 130		5 to 165		
Versions		Double-acting, Double-acting through-rod, Single-acting retracted piston rod, Single acting extended piston rod, Single-acting through-rod, Perforated through-rod, Anti-rotation, Oscillating male, Oscillating female, No stick-slip.										
Sensor magnet		Available magnetic and non-magnetic versions.										
Inrush pressure	single piston rod	0.6	0.6	0.6	0.6	0.6	0.4	0.4	0.4	0.4	0.4	
	through-rod	1	0.8	0.8	0.8	0.6	0.4	0.4	0.4	0.4	0.4	
Forces generated at 6 bar thrust/retraction		See cylinder "General technical data" at the beginning of the chapter										
Weights		See cylinder "General technical data" at the beginning of the chapter										
Notes		For speeds lower than 0.2 m/s to prevent surging, use the version No stick-slip and non-lubricated air. † Maximum recommended strokes. Higher values can create operating problems										

COMPONENTS

- PISTON ROD: C45 steel or stainless steel, thick chromed
- HEAD:
 - Ø 12 to 25 nichel-plated brass
 - Ø 32 to 100 anodized aluminium
- PISTON ROD GASKET: polyurethane, NBR or FKM/FPM
- GUIDE BUSHING: steel strip with bronze and PTFE insert
- BARREL: drawn anodized aluminium alloy
- HALF-PISTON:
 - Ø 12 to 63 acetal resin
 - Ø 80 to 100 in aluminium with PTFE guide pad
- PISTON GASKET: polyurethane, NBR or FKM/FPM
- MAGNET: Ø 12 to 25 neodymium - Ø 32 to 100 plastoferrite
- Static O-rings: NBR or FKM/FPM

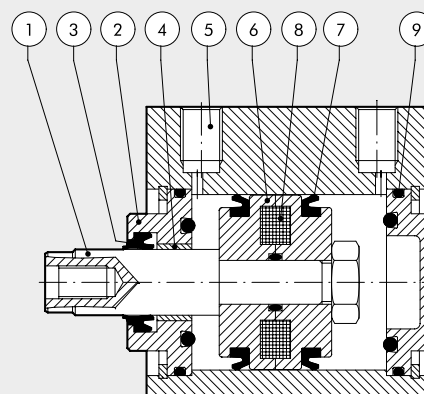

FIXING METHOD

Fix directly from above using long through-screws or tie rods.
Non-magnetic stainless steel must be used (e.g. AISI 304).

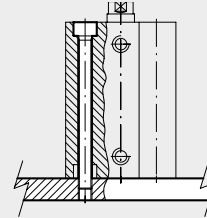

DIMENSIONS STANDARD VERSIONS

+ = ADD THE STROKE

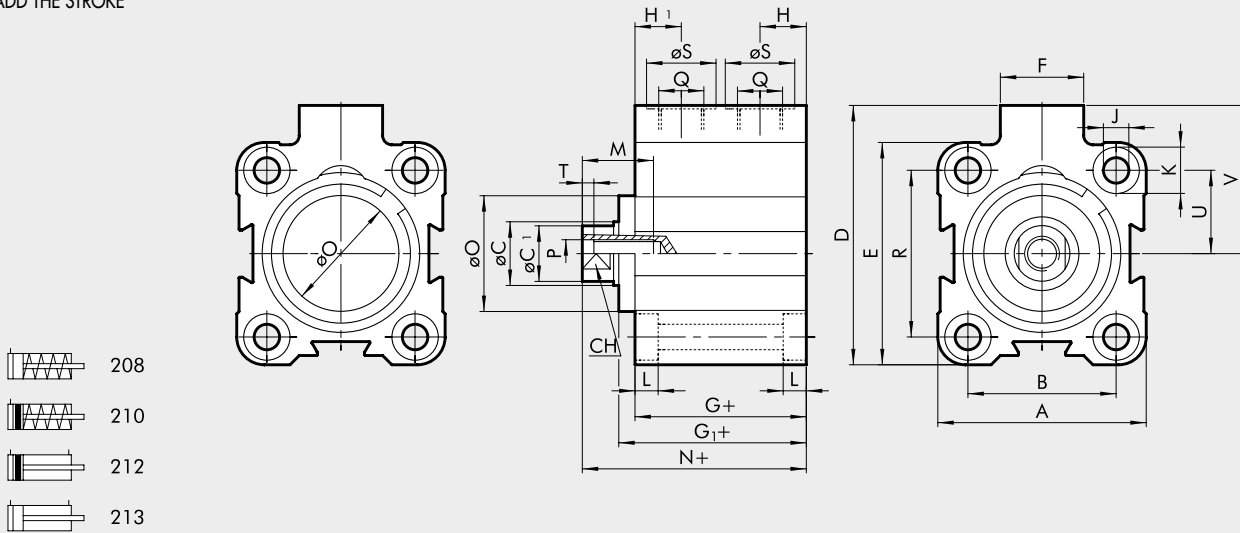

DIMENSIONS OF DOUBLE ACTING

Ø	A	B	øC	øC ₁	D	E	F	G	G ₁	H	H ₁	J	K	L	M	N	øO	P	Q	R	øS	CH	T	U	V
12	23.5	13	6	5.5	28	26	11	32.5	-	6.5	10.5	3.7	6	3.7	7	38	-	M3	M5	-	8	5	2	9.5	16.5
16	28	20	8	7.5	33	28	11	33	-	6.7	10.5	3.7	6	3.7	10	37.5	-	M5	M5	20	8	7	2	10	19
20	32	22	10	9	37	32	11	32	-	6.5	10.5	4.6	7.5	4.6	10	37.6	-	M5	M5	22	8	8	2	11	21
25	37	26	10	9	47.5	39	18	33	36.5	8.5	8.5	4.6	7.5	4.6	10	42.5	20	M5	G1/8	28	15	8	2	14	28
32	45	32	12	11	56	48	18	37	40.8	10	10	5.5	10	5.7	15	48.3	25	M6	G1/8	36	15	10	2.5	18	32
40	54.5	40	12	11	62.7	54.5	18	39.5	44.7	10	10	5.5	10	5.7	15	53.2	30	M6	G1/8	40	15	10	2.5	20	35.5
50	66	50	16	15	73	66	18	39.5	46.2	11	11	6.6	11	6.8	18	54.3	35	M8	G1/8	50	15	13	3.5	25	40
63	80	62	16	15	88	80	23	42	48.7	12	12	9	15	9	18	57.7	35	M8	G1/8	62	15	13	3.5	31	48
80	100	82	20	19	110	100	26	57	67.2	14	14	9	15	9	18	75.2	44	M10	G1/4	82	19	17	4	41	60
100	124	103	25	24	134	124	26	64	74.7	15	15	11	18	11	20	84.3	56	M12	G1/4	103	19	22	5	51.5	72

DIMENSIONS OF SINGLE-ACTING, RETRACTED PISTON ROD

Ø	stroke	A	B	øC	øC ₁	D	E	F	G	G ₁	H	H ₁	J	K	L	M	N	øO	P	Q	R	øS	CH	T	U	V
12	5 to 25	23.5	13	6	5.5	28	26	11	32.5	-	6.5	10.5	3.7	6	3.7	7	38	-	M3	M5	-	8	5	2	9.5	16.5
16	5 to 25	28	20	8	7.5	33	28	11	33	-	6.7	10.5	3.7	6	3.7	10	37.5	-	M5	M5	20	8	7	2	10	19
20	5 to 25	32	22	10	9	37	32	11	32	-	6.5	10.5	4.6	7.5	4.6	10	37.6	-	M5	M5	22	8	8	2	11	21
25	5 to 25	37	26	10	9	47.5	39	18	33	36.5	8.5	8.5	4.6	7.5	4.6	10	42.5	20	M5	G1/8	28	15	8	2	14	28
32	5 to 25	45	32	12	11	56	48	18	37	40.8	10	10	5.5	10	5.7	15	48.3	25	M6	G1/8	36	15	10	2.5	18	32
	> 25 to 50								45	48.8							56.3									
40	5 to 25	54.5	40	12	11	62.7	54.5	18	39.5	44.7	10	10	5.5	10	5.7	15	53.2	30	M6	G1/8	40	15	10	2.5	20	35.5
	> 25 to 50								47.5	52.7							61.2									
50	5 to 25	66	50	16	15	73	66	18	39.5	46.2	11	11	6.6	11	6.8	18	54.3	35	M8	G1/8	50	15	13	3.5	25	40
	> 25 to 50								47.5	54.2							62.3									
63	5 to 25	80	62	16	15	88	80	23	42	48.7	12	12	9	15	9	18	62.3	35	M8	G1/8	62	15	13	3.5	31	48
	> 25 to 50								50	56.7							65.7									

DIMENSIONS OF SINGLE-ACTING EXTENDED PISTON ROD

+ = ADD THE STROKE
 ++ = ADD TWICE THE STROKE

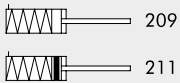
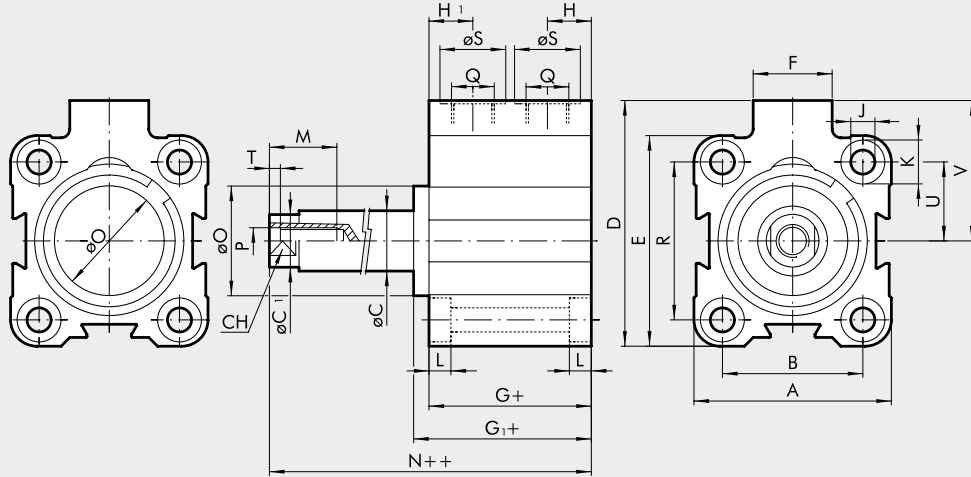

Ø	stroke	A	B	øC	øC ₁	D	E	F	G	G ₁	H	H ₁	J	K	L	M	N	øO	P	Q	R	øS	CH	T	U	V
12	5 to 25	23.5	13	6	5.5	28	26	11	32.5	-	6.5	10.5	3.7	6	3.7	7	38	-	M3	M5	-	8	5	2	9.5	16.5
16	5 to 25	28	20	8	7.5	33	28	11	33	-	6.7	10.5	3.7	6	3.7	10	37.5	-	M5	M5	20	8	7	2	10	19
20	5 to 25	32	22	10	9	37	32	11	32	-	6.5	10.5	4.6	7.5	4.6	10	37.6	-	M5	M5	22	8	8	2	11	21
25	5 to 25	37	26	10	9	47.5	39	18	33	36.5	8.5	8.5	4.6	7.5	4.6	10	42.5	20	M5	G1/8	28	15	8	2	14	28
32	5 to 25	45	32	12	11	56	48	18	37	40.8	10	10	5.5	10	5.7	15	48.3	25	M6	G1/8	36	15	10	2.5	18	32
	> 25 to 50								45	48.8							56.3									
40	5 to 25	54.5	40	12	11	62.7	54.5	18	39.5	44.7	10	10	5.5	10	5.7	15	53.2	30	M6	G1/8	40	15	10	2.5	20	35.5
	> 25 to 50								47.5	52.7							61.2									
50	5 to 25	66	50	16	15	73	66	18	39.5	46.2	11	11	6.6	11	6.8	18	54.3	35	M8	G1/8	50	15	13	3.5	25	40
	> 25 to 50								47.5	54.2							62.3									
63	5 to 25	80	62	16	15	88	80	23	42	48.7	12	12	9	15	9	18	57.7	35	M8	G1/8	62	15	13	3.5	31	48
	> 25 to 50								50	56.7							65.7									

DIMENSIONS OF Ø 12 ANTI-ROTATION

+ = ADD THE STROKE

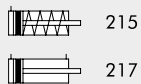
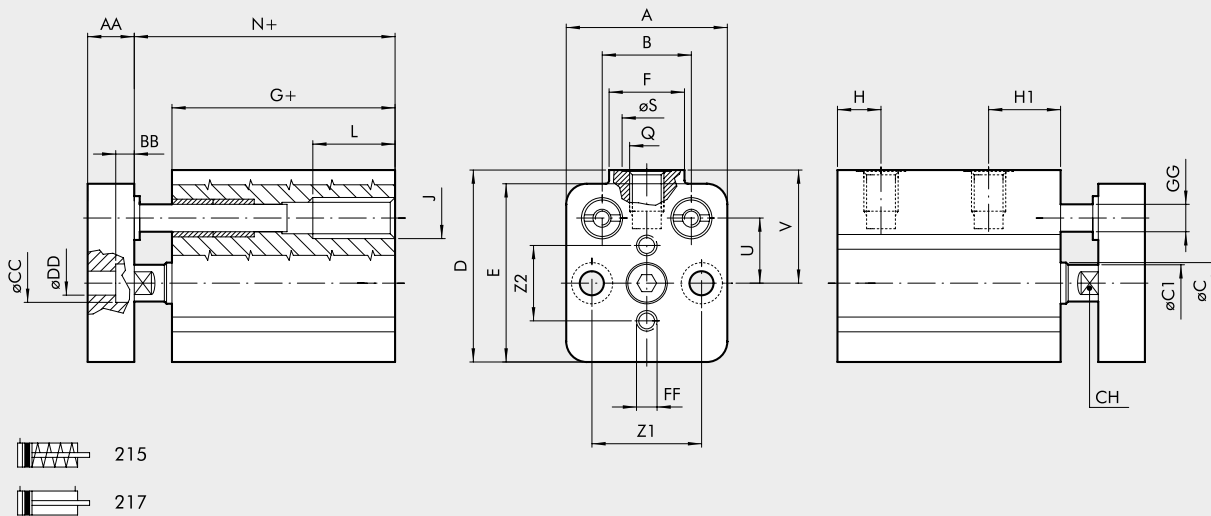

Ø	A	B	øC	øC ₁	D	E	F	G	H	H ₁	J	L	N	Z ₁	Z ₂	Q	øS	CH	U	V	AA	BB	øCC	øDD	FF	øGG
12	23.5	13	6	5.5	28	26	11	32.5	6.5	10.5	M6	12	38	16	11	M5	8	5	9.5	16.5	8	3.5	6	3.5	M3	4

DIMENSIONS OF Ø 16 TO Ø 100 ANTI-ROTATION

+ = ADD THE STROKE

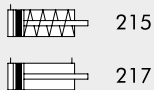
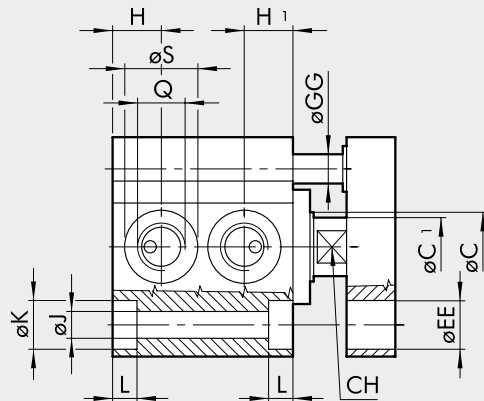
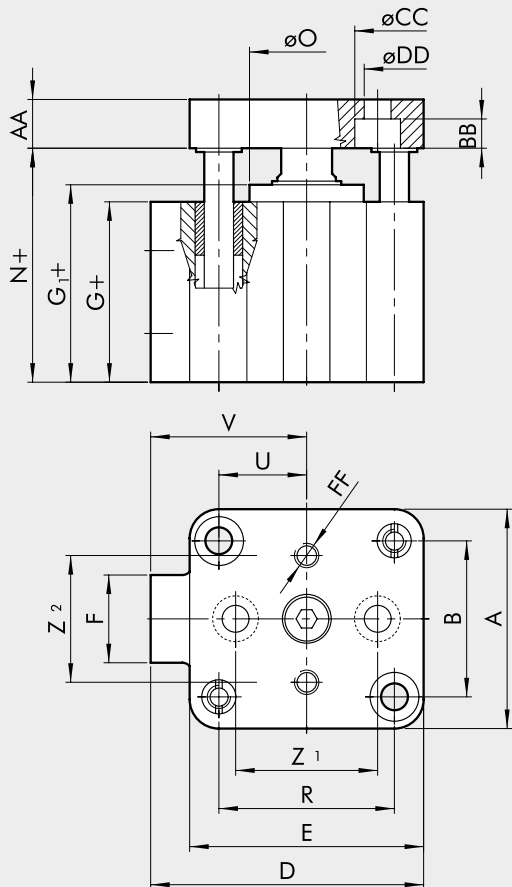

DOUBLE ACTING VERSION (217)

Ø	A	B	øC	øC ₁	D	E	F	G	G ₁	H	H ₁	J	K	L	N	Z ₁	Z ₂	Q	R	øS	CH	U	V	AA	BB	øCC	øDD	øEE	FF	øGG	øO
16	28	20	8	7.5	33	28	11	33	-	6.7	10.5	3.7	6	3.7	37.5	20	15	M5	20	8	7	10	19	8	3.5	6	3.5	6	M3	4	-
20	32	22	10	9	37	32	11	32	-	6.5	10.5	4.6	7.5	4.6	37.6	22	18	M5	22	8	8	11	21	8	5	7.5	4.5	7.5	M4	6	-
25	37	26	10	9	47.5	39	18	33	36.5	8.5	8.5	4.6	7.5	4.6	42.5	22	22	G1/8	28	15	8	14	28	8	5	7.5	4.5	8	M4	6	20
32	45	32	12	11	56	48	18	37	40.8	10	10	5.5	10	5.7	48.3	26	26	G1/8	36	15	10	18	32	10	6	10	5.5	10	M5	8	25
40	54.5	40	12	11	62.7	54.5	18	39.5	44.7	10	10	5.5	10	5.7	53.2	34	34	G1/8	40	15	10	20	35.5	10	6	10	5.5	10	M5	8	30
50	66	50	16	15	73	66	18	39.5	46.2	11	11	6.6	11	6.8	54.3	43	43	G1/8	50	15	13	25	40	12	7	11	6.5	11	M6	10	35
63	80	62	16	15	88	80	23	42	48.7	12	12	9	15	9	57.7	55	55	G1/8	62	15	13	31	48	12	9	14	9	15	M6	10	35
80	100	82	20	19	110	100	26	57	67.2	14	14	9	15	9	75.2	70	70	G1/4	82	19	17	41	60	14	9	14	9	15	M8	12	44
100	124	103	25	24	134	124	26	64	74.7	15	15	11	18	11	84.3	94	94	G1/4	103	19	22	51.5	72	17	9	14	9	18	M8	12	56

SINGLE-ACTING THROUGH-ROD VERSION (215)

Ø	Hub	A	B	øC	øC ₁	D	E	F	G	G ₁	H	H ₁	J	K	L	M	N	øO	P	Q	R	øS	CH	T	U	V
16	5-25	28	20	8	7.5	33	28	11	33	-	6.7	10.5	3.7	6	3.7	10	37.5	-	M5	M5	20	8	7	2	10	19
20	5-25	32	22	10	9	37	32	11	32	-	6.5	10.5	4.6	7.5	4.6	10	37.6	-	M5	M5	22	8	8	2	11	21
25	5-25	37	26	10	9	47.5	39	18	33	36.5	8.5	8.5	4.6	7.5	4.6	10	42.5	20	M5	G1/8	28	15	8	2	14	28
32	5-25	45	32	12	11	56	48	18	37	40.8	10	10	5.5	10	5.7	15	48.3	25	M6	G1/8	36	15	10	2.5	18	32
	> 25-50								45	48.8							56.3									
40	5-25	54.5	40	12	11	62.7	54.5	18	39.5	44.7	10	10	5.5	10	5.7	15	53.2	30	M6	G1/8	40	15	10	2.5	20	35.5
	> 25-50								47.5	52.7							61.2									
50	5-25	66	50	16	15	73	66	18	39.5	46.2	11	11	6.6	11	6.8	18	54.3	35	M8	G1/8	50	15	13	3.5	25	40
	> 25-50								47.5	54.2							62.3									
63	5-25	80	62	16	15	88	80	23	42	48.7	12	12	9	15	9	18	57.7	35	M8	G1/8	62	15	13	3.5	31	48
	> 25-50								50	56.7							65.7									

DIMENSIONS OF THROUGH-ROD

+ = ADD THE STROKE
 ++ = ADD TWICE THE STROKE

PERFORATED THROUGH-ROD

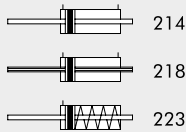
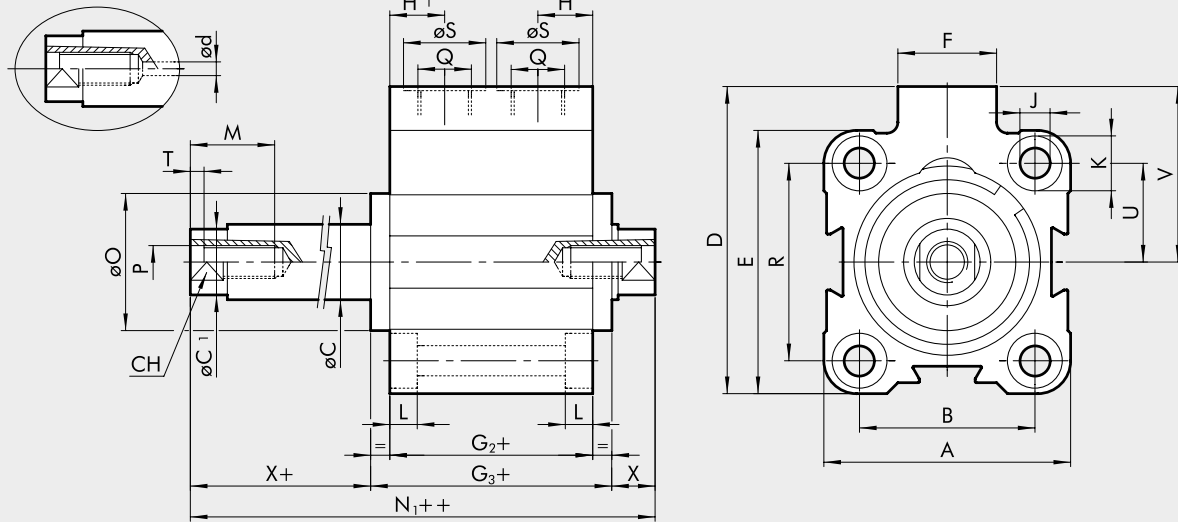

ACTUATORS

SHORT-STROKE CYLINDER – SERIES SSCY

DIMENSION OF DOUBLE ACTING THROUGH-ROD AND PERFORATED THROUGH-ROD

Ø	A	B	øC	øC ₁	D	ød**	E	F	G ₂	G ₃	H	H ₁	J	K	L	M	N ₁	øO	P	Q	R	øS	CH	T	U	V	X*
12	23.5	13	6	5.5	28	-	26	11	36.7	-	10.5	10.5	3.7	6	3.7	7	47.7	-	M3	M5	-	8	5	2	9.5	16.5	5.5
16	28	20	8	7.5	33	-	28	11	36.8	-	10.5	10.5	3.7	6	3.7	10	45.8	-	M5	M5	20	8	7	2	10	19	4.5
20	32	22	10	9	37	1.5	32	11	36	-	10.5	10.5	4.6	7.5	4.6	10	47.2	-	M5	M5	22	8	8	2	11	21	5.6
25	37	26	10	9	47.5	1.5	39	18	35.7	42.7	8.5	8.5	4.6	7.5	4.6	10	54.7	20	M5	G1/8	28	15	8	2	14	28	6
32	45	32	12	11	56	2.5	48	18	37	44.5	10	10	5.5	10	5.7	15	59.5	25	M6	G1/8	36	15	10	2.5	18	32	7.5
40	54.5	40	12	11	62.7	2.5	54.5	18	39.5	49.9	10	10	5.5	10	5.7	15	66.9	30	M6	G1/8	40	15	10	2.5	20	35.5	8.5
50	66	50	16	15	73	2.5	66	18	39.5	52.9	11	11	6.6	11	6.8	18	69.1	35	M8	G1/8	50	15	13	3.5	25	40	8.1
63	80	62	16	15	88	4	80	23	42	55.4	12	12	9	15	9	18	73.4	35	M8	G1/8	62	15	13	3.5	31	48	9
80	100	82	20	19	110	5	100	26	57	77.4	14	14	9	15	9	18	93.4	44	M10	G1/4	82	19	17	4	41	60	8
100	124	103	25	24	134	6	124	26	64	85.4	15	15	11	18	11	20	104.6	56	M12	G1/4	103	19	22	5	51.5	72	9.6

* for Ø 12, 16, 20: (N₁₊₊) = (G₂₊) + (X) + (X+)
 ** column for perforated through-rod only

DIMENSION OF SINGLE-ACTING THROUGH-ROD

Ø	stroke	A	B	øC	øC ₁	D	E	F	G ₂	G ₃	H	H ₁	J	K	L	M	N ₁	øO	P	Q	R	øS	CH	T	U	V	X*
12	5 to 25	23.5	13	6	5.5	28	26	11	36.7	-	10.5	10.5	3.7	6	3.7	7	47.7	-	M3	M5	-	8	5	2	9.5	16.5	5.5
16	5 to 25	28	20	8	7.5	33	28	11	36.8	-	10.5	10.5	3.7	6	3.7	10	45.8	-	M5	M5	20	8	7	2	10	19	4.5
20	5 to 25	32	22	10	9	37	32	11	36	-	10.5	10.5	4.6	7.5	4.6	10	47.2	-	M5	M5	22	8	8	2	11	21	5.6
25	5 to 25	37	26	10	9	47.5	39	18	35.7	42.7	8.5	8.5	4.6	7.5	4.6	10	57.7	20	M5	G1/8	28	15	8	2	14	28	6
32	5 to 25	45	32	12	11	56	48	18	37	44.5	10	10	5.5	10	5.7	15	59.5	25	M6	G1/8	36	15	10	2.5	18	32	7.5
	> 25 to 50								45	52.5							67.5										7.5
40	5 to 25	54.5	40	12	11	62.7	54.5	18	39.5	49.9	10	10	5.5	10	5.7	15	66.9	30	M6	G1/8	40	15	10	2.5	20	35.5	8.5
	> 25 to 50								47.5	57.9							74.9										8.5
50	5 to 25	66	50	16	15	73	66	18	39.5	52.9	11	11	6.6	11	6.8	18	69.1	35	M8	G1/8	50	15	13	3.5	25	40	8.1
	> 25 to 50								47.5	60.9							77.1										8.1
63	5 to 25	80	62	16	15	88	80	23	42	55.4	12	12	9	15	9	18	73.4	35	M8	G1/8	62	15	13	3.5	31	48	9
	> 25 to 50								50	63.4							81.4										9

* for Ø 12, 16, 20: (N₁₊₊) = (G₂₊) + (X) + (X+)

DIMENSIONS: SAME AS 221 VERSION (MALE HINGE MOD. BA) - SAME AS 222 VERSION (FEMALE HINGE MOD. B)

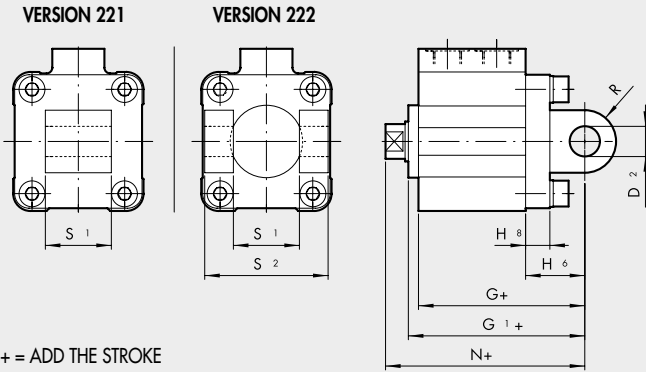

+ = ADD THE STROKE

Ø	Stroke	D ₂	G	G ₁	H ₆	H ₈	N	R	S ₁	S ₂
32	5 to 70	10	59	62.8	22	10	70.3	11	26	45
40	5 to 70	12	64.5	69.7	25	10	78.2	13	28	52
50	5 to 110	12	66.5	73.2	27	12	80.2	13	32	60
63	5 to 110	16	74	80.7	32	12	89.7	17	40	70

Note: For other dimensions, refer to the standard version

KEY TO CODES

CYL	2 1 2 TYPE	0	4 0 BORE	0 0 1 0 STROKE	C MATERIAL	P GASKETS
■	208 Single-acting retracted rod, non-magnetic	0 Standard	12	For the maximum applicable strokes, look at the technical data	C C45 chrome piston rod, technopolymer piston Ø 12 to 63 mm	P Polyurethane gaskets
■	209 Single-acting extended rod, non-magnetic	S Non-magnetic	16		A C45 chrome piston rod, aluminium piston (standard Ø 80 to 100 mm)	N NBR gaskets
■	210 Single-acting, retracted rod	▲ G No stick-slip	20		X Stainless steel piston rod and nut	● V FKM/FPM gaskets
■	211 Single acting, extended rod		25		Z Stainless steel piston rod and nut	● B Low temperature
■	212 Double acting, magnetic		32			
■	213 Double acting, non-magnetic		40			
■	214 Double acting, through-rod		50			
■	215 Single-acting, retracted, anti-rotation		63			
■	217 Double acting, anti-rotation		80			
▼	218 Double acting, perforated through-rod		◆ 100			
	221 Oscillating male hinge (up to Ø 63 only)					
	222 Oscillating female hinge (up to Ø 63 only)					
■	223 Single-acting, through-rod					

- ◆ In the code of cylinder with letter in fourth position Ø 100 becomes A1
- Available up to Ø 63
- ▼ Available from Ø 20

- Only available for non-magnetic versions (S) and with aluminium piston (A or Z)
- ▲ For speeds lower than 0.2 m/s, to prevent surging. Use no-lubricated air only

ACCESSORIES

MALE NIPPLE FOR PISTON ROD

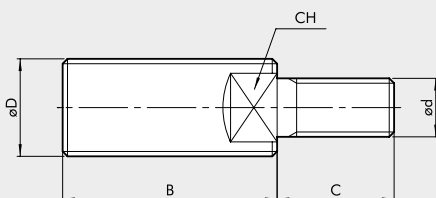

Code	Ø	Ø D	Ø d	B	C	CH	Weight [g]
219001200	12	M6	M3	16	6	4	3
219001600	16	M8	M5	20	9	6	8
219001600	20	M8	M5	20	9	6	8
219002500	25	M10x1.25	M5	22	9	7	12
219003200	32	M10x1.25	M6	22	12	7	14
219004000	40	M12x1.25	M6	24	12	10	14
219005000	50	M16x1.5	M8	32	15	13	20
219005000	63	M16x1.5	M8	32	15	13	20
219008000	80	M20x1.5	M10	40	15	17	96
219010000	100	M20x1.5	M12	40	18	17	102

MAGNETIC SENSORS

SENSOR SERIES DCB

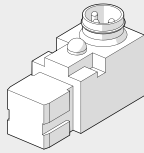

For codes and technical data, see **chapter A6**.

RETRACTABLE SENSOR

SENSOR, SQUARE TYPE

Latest generation, secure fixing

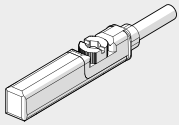

SENSOR, OVAL TYPE

Traditional

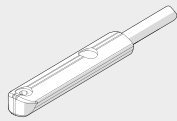

For codes and technical data, see **chapter A6**.

ADAPTER FOR RETRACTABLE SENSOR SQUARE AND OVAL TYPES

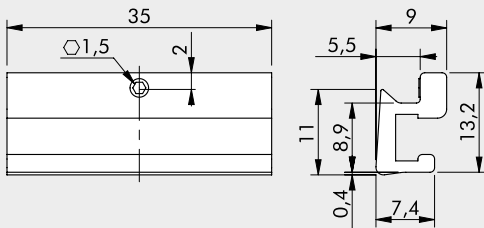

Code	Ø	Description
W0950001101	Ø 12 to 100	Sensor Adapter for SSC cylinders

ASSEMBLY DIAGRAM

- ① SSCY cylinder
- ② Sensor adapter for SSCY cylinders
- ③ Retractable sensor "oval type"
- ④ Retractable sensor "square type"
- ⑤ Grub screw for fixing adapter on profile

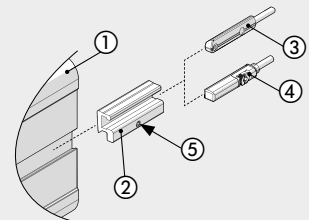

SPARES PARTS FOR SHORT-STROKE CYLINDERS

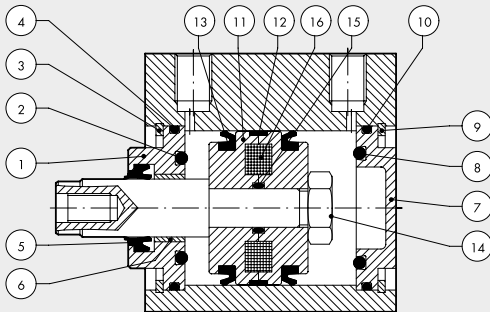

Code	Bores	Type	Parts
009 ... 0010	Ø 12 to 100	Complete polyurethane front head kit	① ② ③ ④ ⑤ ⑥
009 ... 0011	Ø 12 to 100	Complete NBR front head kit	① ② ③ ④ ⑤ ⑥
009 ... 0015	Ø 12 to 100	Complete NBR rear head kit	⑦ ⑧ ⑨ ⑩
009 ... 0021	Ø 12 to 100	Complete polyurethane piston kit	⑪ ⑫ ⑬ ⑭ ⑮
009 ... 0023	Ø 12 to 100	Complete NBR piston kit	⑪ ⑫ ⑬ ⑭ ⑮
009 ... 0005	Ø 12 to 100	Complete set of polyurethane gaskets	② ④ ⑤ ⑧ ⑩ ⑬ ⑮
009 ... 0006	Ø 12 to 100	Complete set of NBR gaskets	② ④ ⑤ ⑧ ⑩ ⑬ ⑮
009 ... 0007	Ø 12 to 100	Complete set of (high temperature) FKM/FPM gaskets	② ④ ⑤ ⑧ ⑩ ⑬ ⑮
009 ... 2008	Ø 12 to 63	Polyurethane piston rod gasket kit	⑤
009 ... 2008	Ø 80 to 100	Polyurethane piston rod gasket kit + seeger	⑤
009 ... 2009	Ø 12 to 63	NBR piston rod gasket kit	⑤
009 ... 2009	Ø 80 to 100	NBR piston rod gasket kit + seeger	⑤
009 ... 2010	Ø 12 to 63	FKM/FPM piston rod gasket kit	⑤
009 ... 2010	Ø 80 to 100	FKM/FPM piston rod gasket kit + seeger	⑤
009 ... 0031	Ø 12 to 100	Complete polyurethane front+rear head kit + piston	① ② ③ ④ ⑤ ⑥ ⑦ ⑧ ⑨ ⑩ ⑪ ⑫ ⑬ ⑭ ⑮
009 ... 0033	Ø 12 to 100	Complete NBR front + rear head kit + piston	① ② ③ ④ ⑤ ⑥ ⑦ ⑧ ⑨ ⑩ ⑪ ⑫ ⑬ ⑭ ⑮
009 ... 0001	Ø 12 to 100	Magnet	⑯