

527 SERIES

Vertical Hold Down Clamps | Product Overview

Features:

- Hardened steel bushings at pivot points
- Solid bar can be modified to suit application requirements
- Thumb lever on link for easy opening

Applications:

- Assembly & test
- Light machining
- Woodworking

527
Flanged Base



527-F ⓘ
Front Mount



Technical Information

Model	Max. Holding Capacity	Clamp Bar Opening (+10°)	Handle Opening (+10°)	Weight
527	4450 N [1000 lbf]	195°	65°	[2.50 lbs] 1,13 kg
527-F ⓘ				

ⓘ This item is available upon request

Holding Capacities | Dimensions

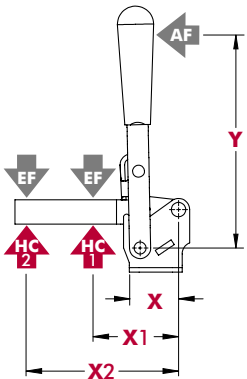

Model	X	X1	X2	Y	±HC1	±HC2	±EF(X1):AF	±EF(X2):AF
527	[3.12] 79,2	[3.50] 89,0	[6.00] 152,4	[4.00] 101,6	[1000 lbf]	[580 lbf]	23:1	12:1
527-F	[2.53] 64,3				4450 N	2580 N		

Dimensions shown "mm [inch]" ± HC = Holding Capacity, EF = Exerting Force, AF = Applied Force
See page MC-TEC-4 for additional information.

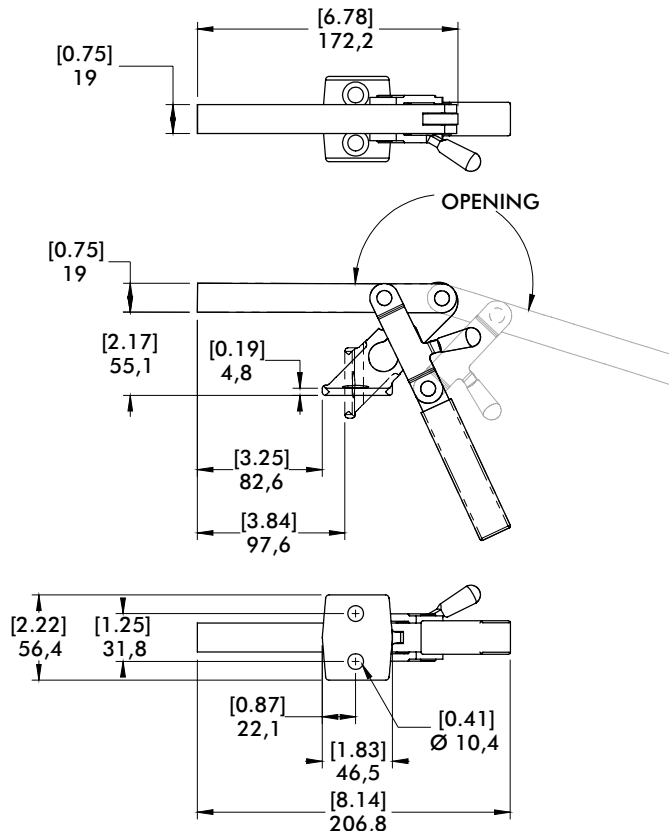
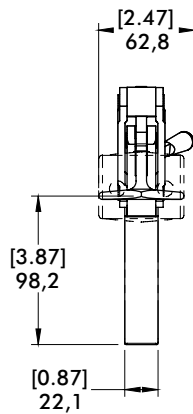

mm [INCH]
THIRD ANGLE PROJECTION