

247, 267 SERIES

Vertical Hold Down Clamps | Product Overview

Features:

- Hardened steel bushings
- Large bar guides for greater lateral stability on Model 247
- Series 247 accommodates M12 or 1/2 spindle accessory
- Series 267 accommodates M16 or 5/8 spindle accessory

Applications:

- Assembly & test
- Light machining
- Welding

Also Available:

See page MC-ACC-1 for accessories
 847-U Pneumatic Toggle Clamp
 (See page MC-PTC-13)
 847-S Pneumatic Toggle Clamp
 (See page MC-PTC-13)

247-U
Flanged Base
U-Bar



247-S
Flanged Base
Solid Bar



267-U
Flanged Base
U-Bar



267-S①
Flanged Base
Solid Bar



Note:
Clamps shown with included accessories.

Technical Information

Model	Max. Holding Capacity	Clamp Bar Opening (+10°)	Handle Opening (+10°)	Weight	Accessories (Supplied)		
					Bolt Retainer	Spindle Assembly	Flanged Washers
247-U	4400 N [1000 lbf]	120°	67°	1,07 kg [2.36 lbs]	---	247208-M	247109
247-S				1,08 kg [2.36 lbs]	247110	---	---
267-U	5340 N [1200 lbf]	140°	72°	2,18 kg [4.80 lbs]	---	267203-M	267102
267-S①				1,98 kg [4.36 lbs]	110122	---	---

① This item is available upon request

Holding Capacities

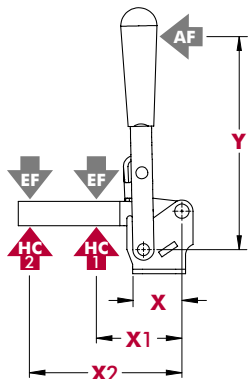

Model	X	X1	X2	Y	±HC1	±HC2	±EF(X1):AF	±EF(X2):AF
247-U	[1.69]	[3.00] 76,2	[6.13] 155,7	[6.71]	[1000 lbf] 4450 N	[480 lbf] 2140 N	12:1	6:1
247-S	43	[4.56] 115,8	[7.00] 177,8	170,5		[650 lbf] 2900 N	10:1	5:1
267-U	[2.50]	[4.00] 101,6	[8.00] 203,2	[9.25]	[1200 lbf] 5340 N	[600 lbf] 2670 N	18:1	8:1
267-S①	63,5	[6.00] 152,4	[8.75] 222,3	235		[820 lbf] 3650 N	12:1	

Dimensions shown "mm [inch]" ± HC = Holding Capacity, EF = Exerting Force, AF = Applied Force
 See page MC-TEC-4 for additional information. ① This item is available upon request

247, 267 SERIES

Vertical Hold Down Clamps | Dimensions | -U/-S/-UB

247-U
Flanged Base
U-Bar

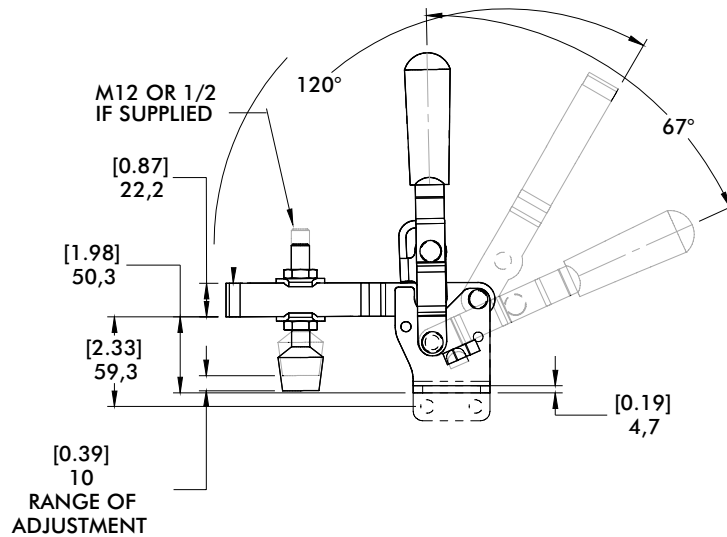
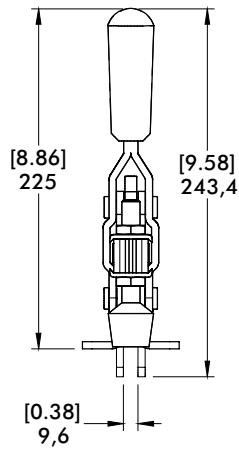
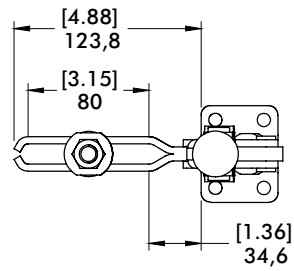

247-S
Flanged Base
Solid Bar

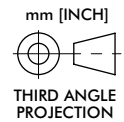
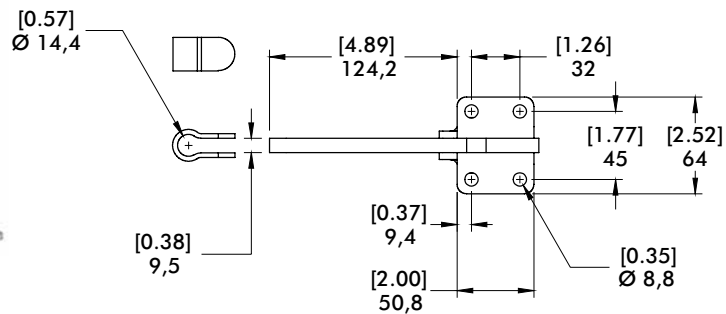

267 SERIES

Vertical Hold Down Clamps | Dimensions

267-U
Flanged Base
U-Bar

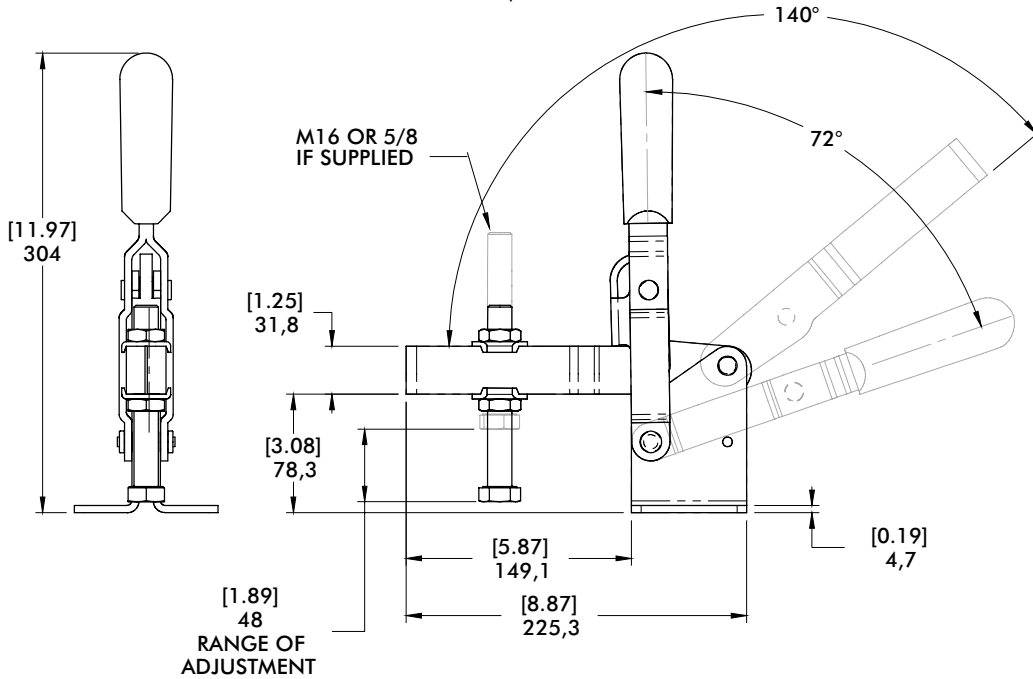
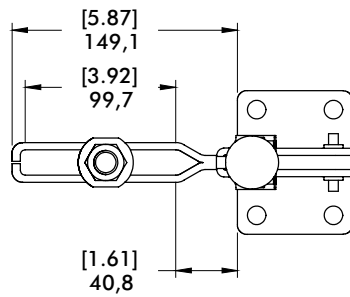

267-S ⓘ
Flanged Base
Solid Bar

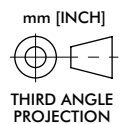
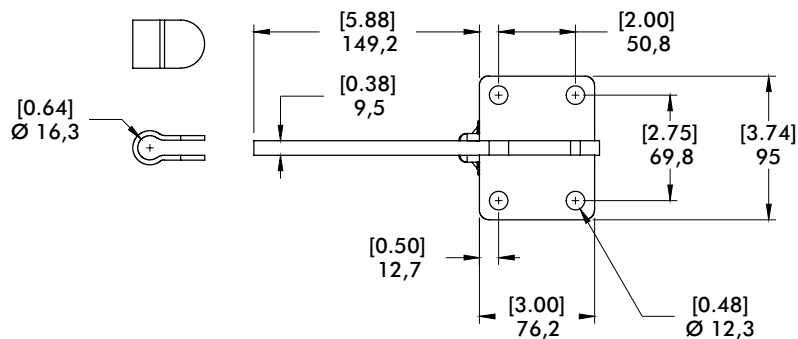

VERTICAL HOLD DOWN CLAMPS

Application Examples

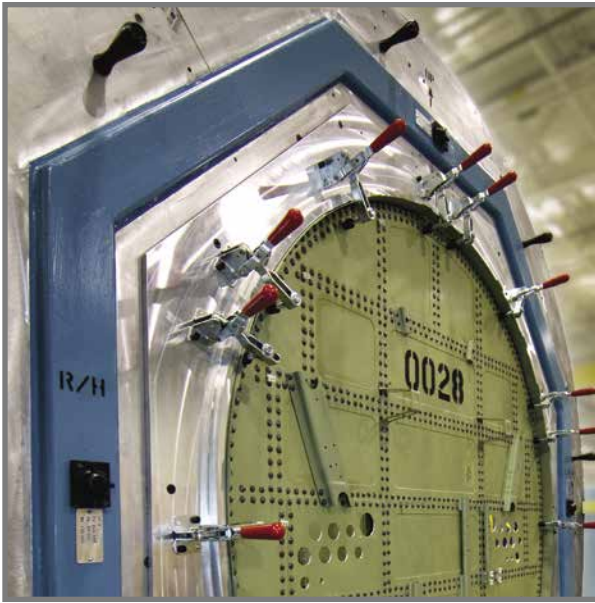

Model 210-U
used in an airframe
assembly fixture

Model 210-U
shown being used
in a checking fixture
application.



Model 533-LB
and **227-UB** shown
with black finish in
a fixture for used for
optical inspection.