

2010 SERIES

Vertical Hold Down Clamps | Product Overview

Features:

- Large hand clearance for improved safety
- Bolt pattern interchangeable with 210 Series
- Over two times the holding capacity of 210 Series
- Hardened bushings at key pivot points
- Near vertical clamping contact

Applications:

- Checking fixtures
- Assembly & test
- Light machining
- Woodworking

Also Available:

See page MC-ACC-1 for accessories
Accepts M10 or 3/8 spindle accessories

Covered under one or more U.S./International Patents

2010-U
Flanged Base
U-Bar



2010-S
Flanged Base
Solid Bar



2010-UB
Straight Base
U-Bar



2010-SB
Straight Base
Solid Bar



2010-UR
Flanged Base
U-Bar
DESTACO®
Toggle Lock
Plus



2010-SR[ⓘ]
Flanged Base
Solid Bar
DESTACO®
Toggle Lock
Plus



2010-UBR
Straight Base
U-Bar
DESTACO®
Toggle Lock
Plus



2010-SBR[ⓘ]
Straight Base
Solid Bar
DESTACO®
Toggle Lock
Plus



Technical Information

Model	Max. Holding Capacity	Clamp Bar Opening (+10°)	Handle Opening (+10°)	Weight	Accessories (Supplied)		
					Bolt Retainer	Spindle Assembly	Flanged Washers
2010-U	6230 N [1400 lbf]	78°	66°	1,16 kg [2.56 lbs]	---	240208-M	235106
2010-S					2010115-E	---	
2010-UB					---	240208-M	235106
2010-SB					2010115-E	---	
2010-UR					---	240208-M	235106
2010-SR [ⓘ]					2010115-E	---	
2010-UBR					---	240208-M	235106
2010-SBR [ⓘ]					2010115-E	---	

[ⓘ] This item is available upon request

2010 SERIES

Vertical Hold Down Clamps | Holding Capacities

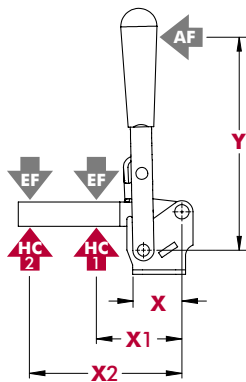

Model	X	X1	X2	Y	±HC1	±HC2	±EF(X1):AF	±EF(X2):AF
2010-()	[2.04] 51,8	[2.44] 62	[4.88] 124	[7.00] 178	[1400 lbf] 6230 N	[720 lbf] 3200 N	13:1	6:1

Dimensions shown "mm [inch]" ± HC = Holding Capacity, EF = Exerting Force, AF = Applied Force
See page MC-TEC-4 for additional information.

Dimensions | -U/-S/-UB/-SB/-UR/-SR/-UBR/-SBR

2010-U
Flanged Base
U-Bar

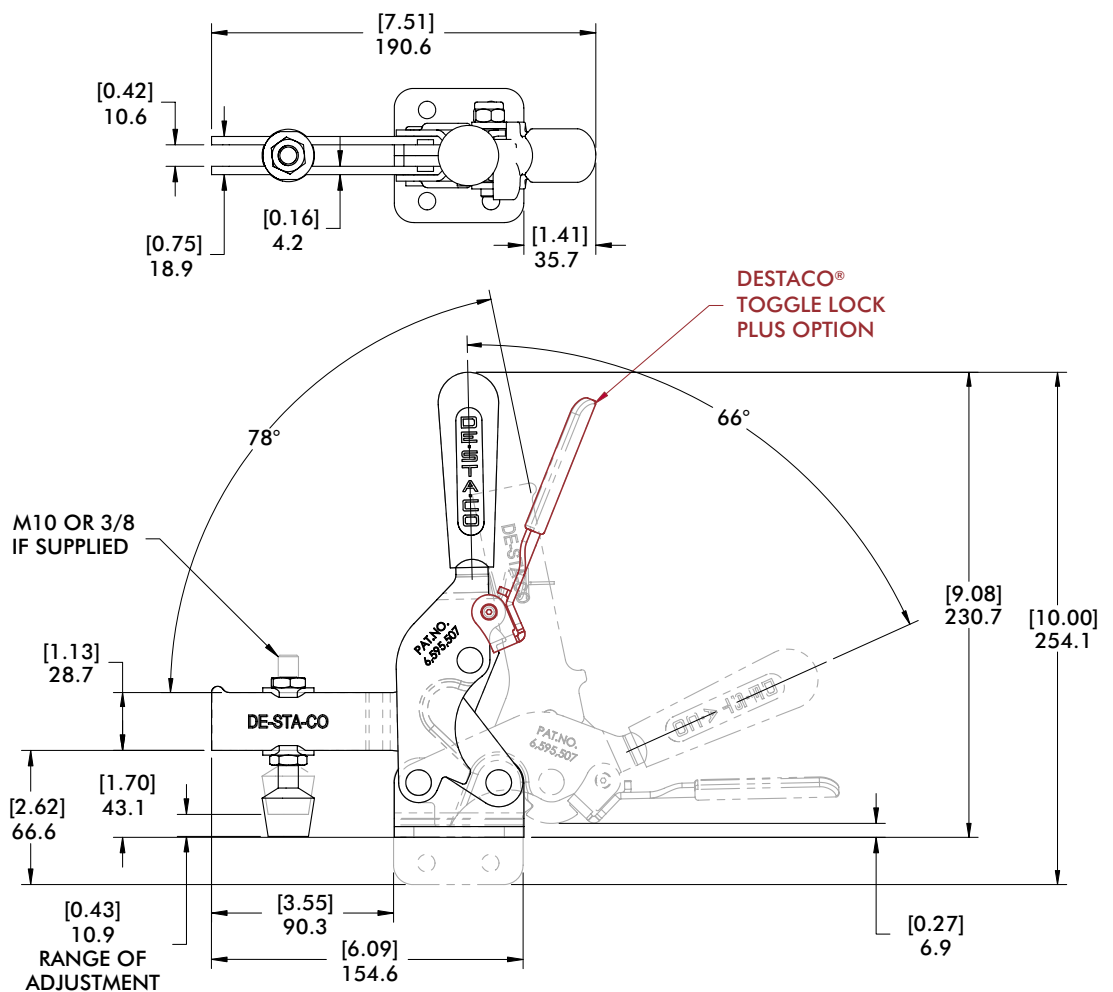

2010-SB
Straight Base
Solid Bar

